

ASSEMBLY INSTRUCTION

Note:

- Read Instructions carefully.
- Carefully identify each component especially those that are similar.
- Separate and identify each component from the hardware pack and rest each one in its proper location before fastening.
- Do not over tighten the screws or bolts when assembling.



2 Persons

TOOL REQUIRED

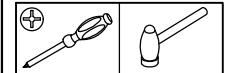

Step 1

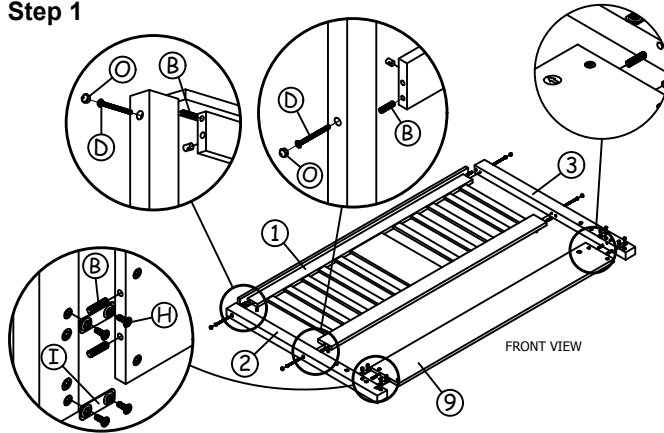

Attach the headboard frame (1) and back storage panel (9) to the left wooden post (2) and right wooden post (3). Secure the headboard frame using hardware parts **B, D** and **O**, then secure the back storage panel with hardware parts **B, H** and **I**.

Step 4

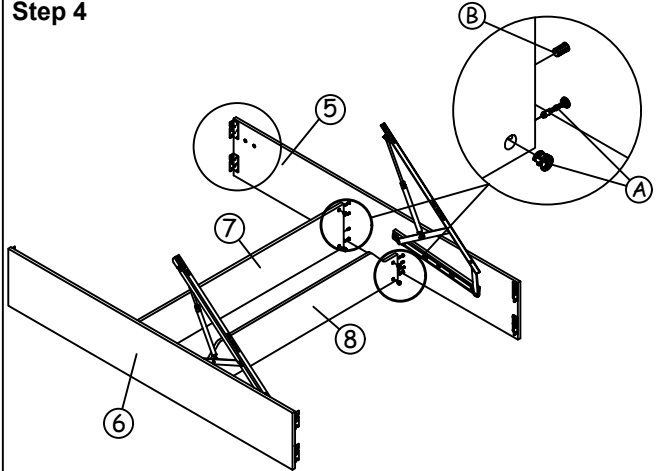

Join together the left side rail (5) and right side rail (6) with the centre storage panels (7) and centre storage panels (8) by using hardware parts **A** and **B**.

Step 2

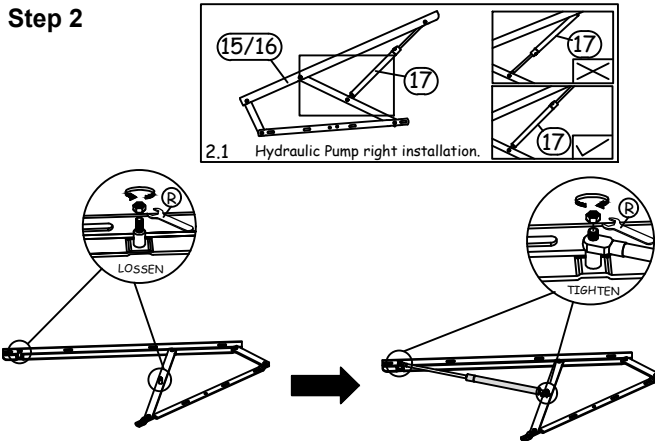

Firstly, Loosen the **Hex Nut** from the Left & Right Hydraulic Base Support ,then fix the hydraulic pump to each hydraulic base using the same **Hex Nut** & **V**. (shown in diagram 2.1.)

Step 5

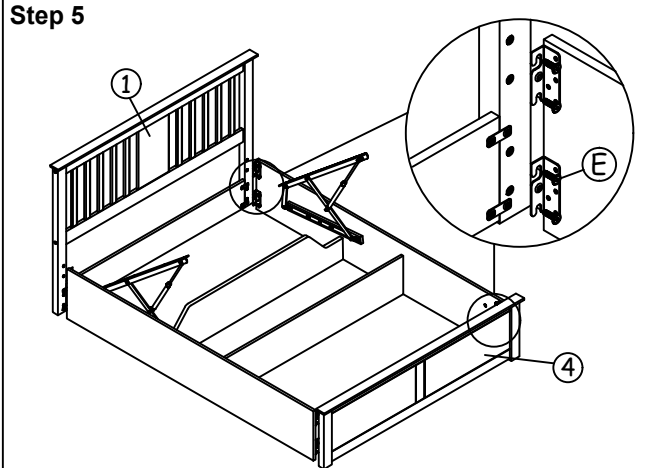

Fix side rail to the headboard and footboard with hardware as shown.

Step 3

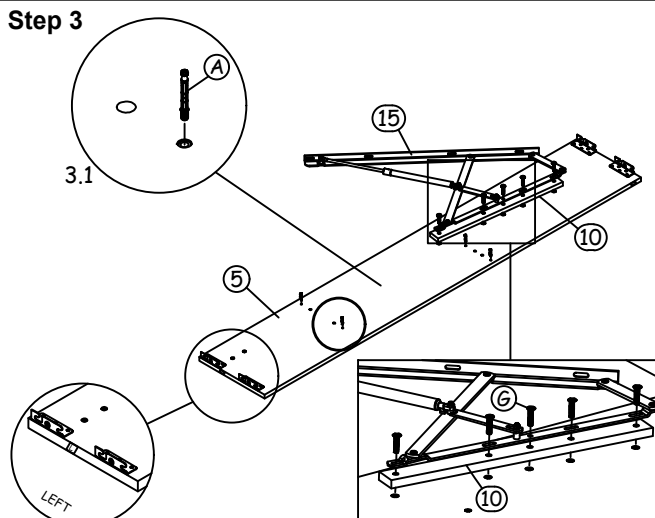

Fix the left & right hydraulic spacer together with hydraulic base supporter to the both side rails using bolts **G** and than screw the minifix part **A** to the both side rails as shown in diagram 3.1.

Step 6

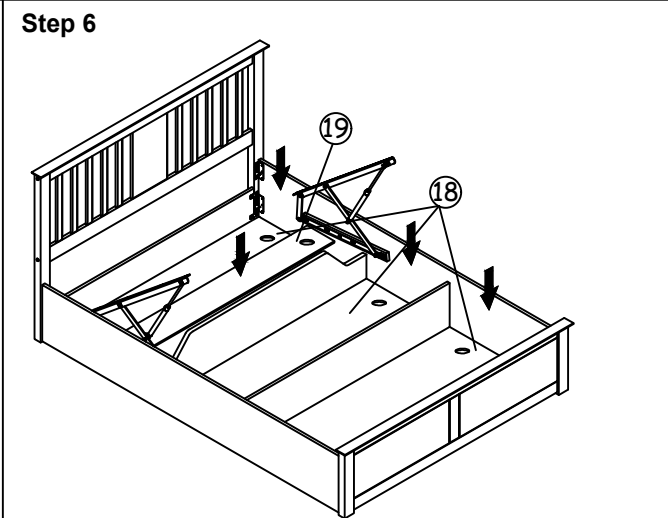

Insert the large base panel (18) and small base panel (19) . **DO NOT** use any power tools as this may damage the frame and will invalidate any claim.

Please follow our assembly instruction procedure for easier assemble.

Step 7

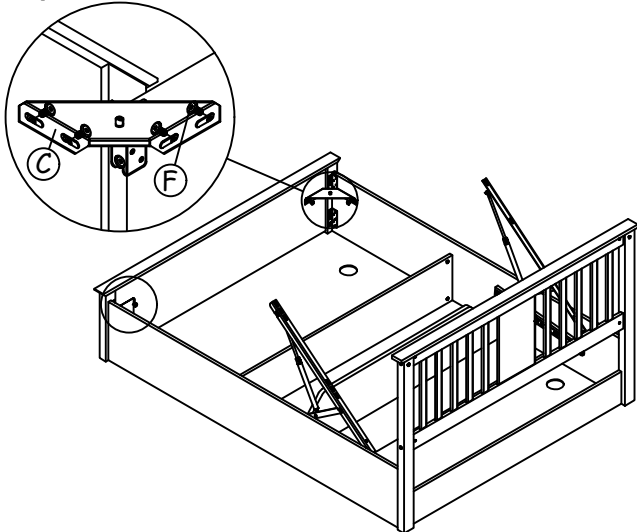

Fix metal corner block **C** to the edge of footboard and side rails with bolt **F** as shown.

Step 8

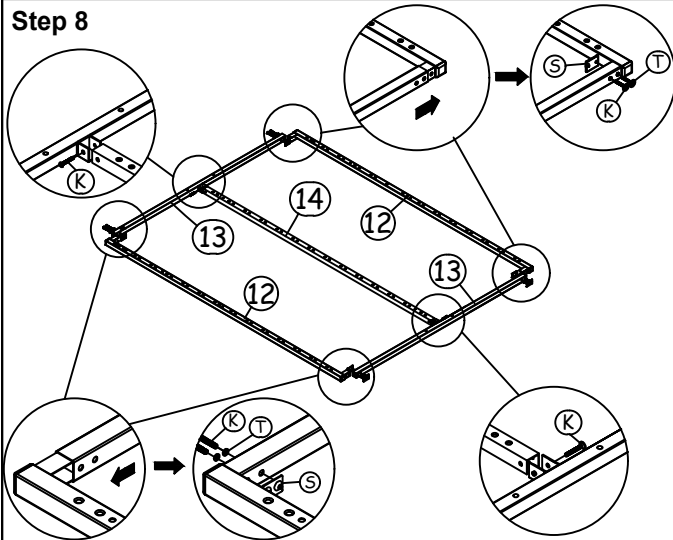

Join together all the bed base parts (12),(13), and (14) by using hardware parts **K,S,T**.
Important note: Please assemble follow arrow direction.
 DO NOT use any power tools as this may damage the frame and will invalidate any claim.

Step 9

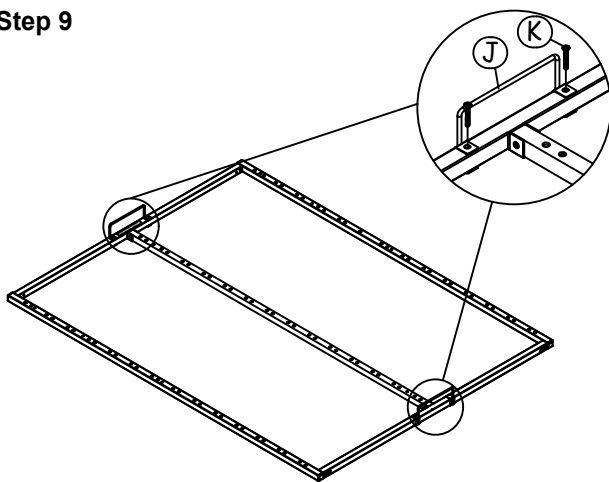

Attach hardware parts **J** using hardware part **K**.
Important note: Please assemble follow arrow direction.
 DO NOT use any power tools as this may damage the frame and will invalidate any claim.

Step 10

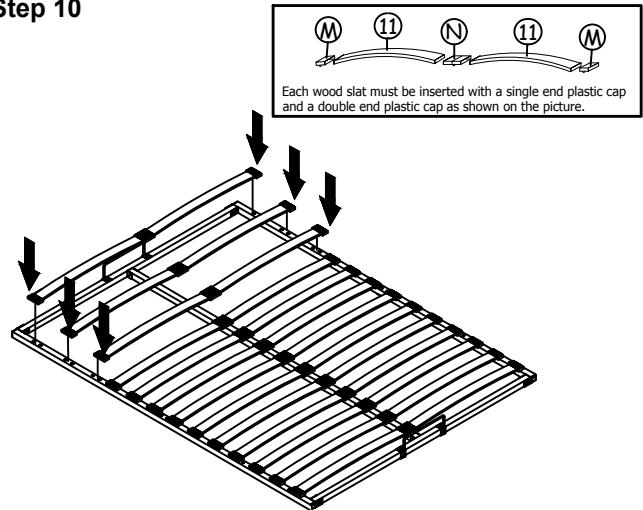

Insert the slats (11) to hardware parts **M** and **N** then press into the base making sure they are secure.

Step 11

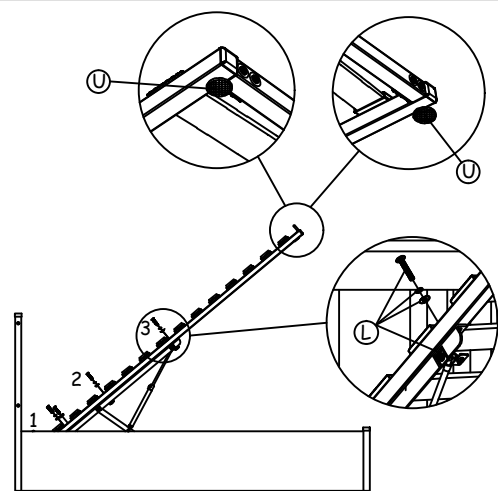

Assemble the bed base on the right & left hydraulic frame and fix bolts **L** starting from '1' to '3' as shown and stick it the self adhesive **U** as shown.
Important note : Do not tighten the bolts yet!



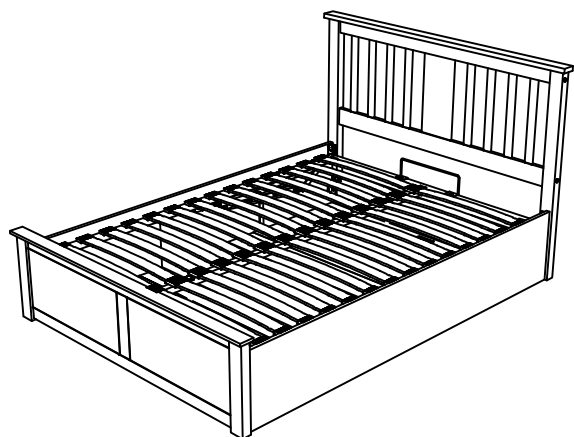







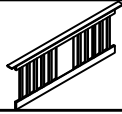

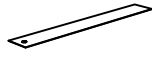

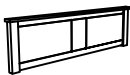

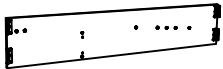

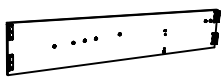







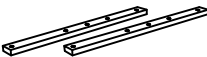





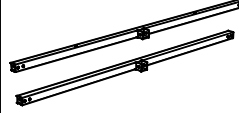
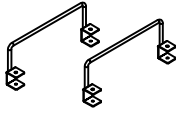

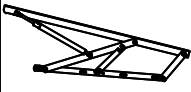

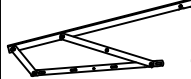
Step 12



THE BED HAS BEEN FULLY ASSEMBLED.

Please follow our assembly instruction procedure for easier assemble.

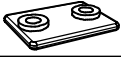
HARDWARE & PART LIST

PART LIST			NO.	ITEM	QTY.
1	 HEADBOARD FRAME	1 PC	18	 BOTTOM BASE PANEL - BIG	3 PCS
2	 WOOD POST (L)	1 PC	19	 BOTTOM BASE PANEL - SMALL	1 PC
3	 WOOD POST (R)	1 PC	HARDWARE LIST		
4	 FOOTBOARD	1 PC	A	 MINI FIX	8 PCS
5	 SIDE RAIL (L)	1 PC	B	 8 X 30 mm WOODEN DOWEL	16 PCS
6	 SIDE RAIL (R)	1 PC	C	 METAL CORNER BLOCK	2 PCS
7	 CENTRE STORAGE PANEL 1	1 PC	D	 M6 X 90 mm BARREL NUT RBW	4 PCS
8	 CENTRE STORAGE PANEL 2	1 PC	E	 M8 X 25 mm JCBB BOLT RBW	16 PCS
9	 BACK STORAGE PANEL	1 PC	F	 M8 X 15 mm JCBB BOLT RBW	8 PCS
10	 HYDRAULIC ARM SPACER	2 PCS	G	 M8 X 35 mm JCBB BOLT RBW	10 PCS
11	 SLAT	28 PCS	H	 M6 X 15 mm JCBC BOLT RBW	8 PCS
12	 LEFT & RIGHT SIDE METAL BAR	2 PCS	I	 BRACKET 20 mm X 580 mm	4 PCS
13	 HEADBOARD & FOOTBOARD END METAL BAR	2 PCS	J	 BASE HANDLE	2 PCS
14	 CENTER METAL BAR	1 PC	K	 M6 X 40 mm JCBC BOLT BLK	14 PCS
15	 LEFT HYDRAULIC BASE SUPPORT c/w PUMP STOPPER	1 PC	L	 M8 X 45 mm JCBB BOLT RBW WITH NUT, BRACKET, SPRING WASHER AND FLAT WASHER	6 PCS
16	 RIGHT HYDRAULIC BASE SUPPORT	1 PC	M	 SINGLE SLAT CAP	28 PCS
17	 HYDRAULIC PUMP	2 PCS	N	 DOUBLE SLAT CAP	14 PCS
			O	 WOODEN BUTTON	4 PCS
			P	 M4 ALLEN KEY	1 PC
			Q	 M5 ALLEN KEY	1 PC
			R	 M12.8 SPANNER	1 PC
			S	 NUT BRACKET	4 PCS
			T	 FLAT WASHER BLK	8 PCS
			U	 SELF ADHESIVE 4mm X 35mm	2 PCS

CAUTION : KEEP ALL HARDWARE PARTS OUT OF REACH OF CHILDREN

Please follow our assembly instruction procedure for easier assemble.

CAUTION :

PLEASE USE HYDRAULIC PUMP STOPPER FOR SAFETY PURPOSE.

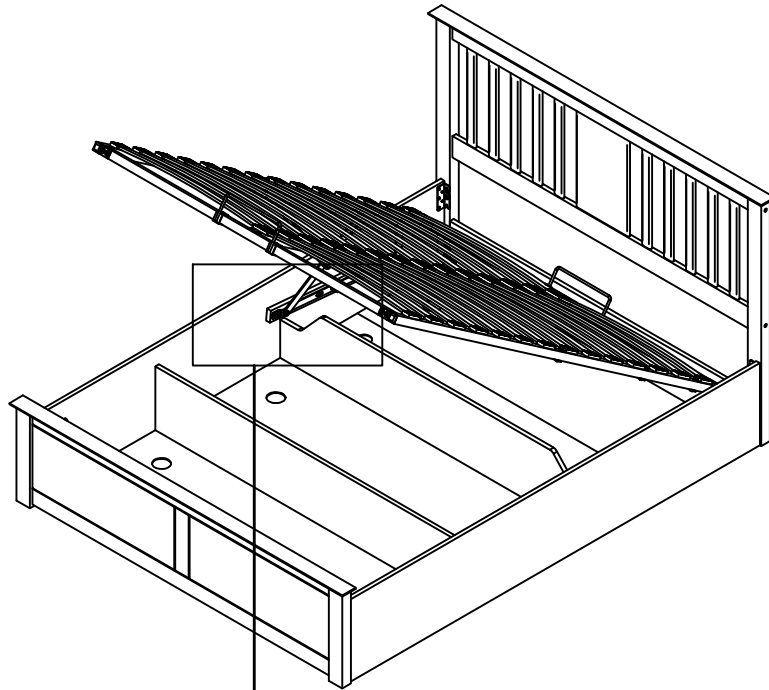

HYDRAULIC PUMP STOPPER

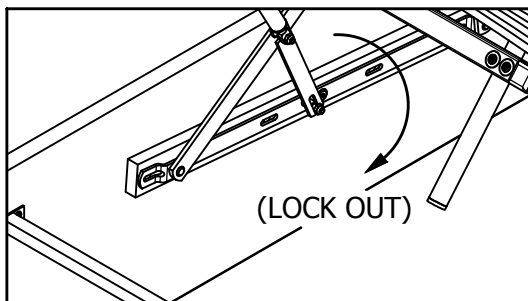
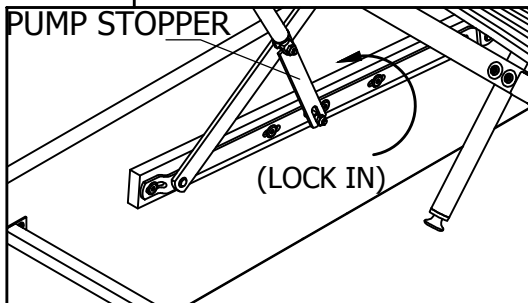

" IMPORTANT NOTE "

WHEN THE BED IS BUILT AND THE MATTRESS FRAME IS AT 45 DEGREE
PLEASE PLACE THE MATTRESS ON THE BED.
PLEASE NOTE THAT THE WEIGHT OF THE MATTRESS IS REQUIRED TO
HELP CLOSE THE BED.
TO LOWER THE SLEEPING PLATFORM STAND AT THE FOOT END OF THE
BED AND PUSH SHARPLY
DOWNWARDS USING BOTH HANDS.

